

System design examples - Access Control Systems

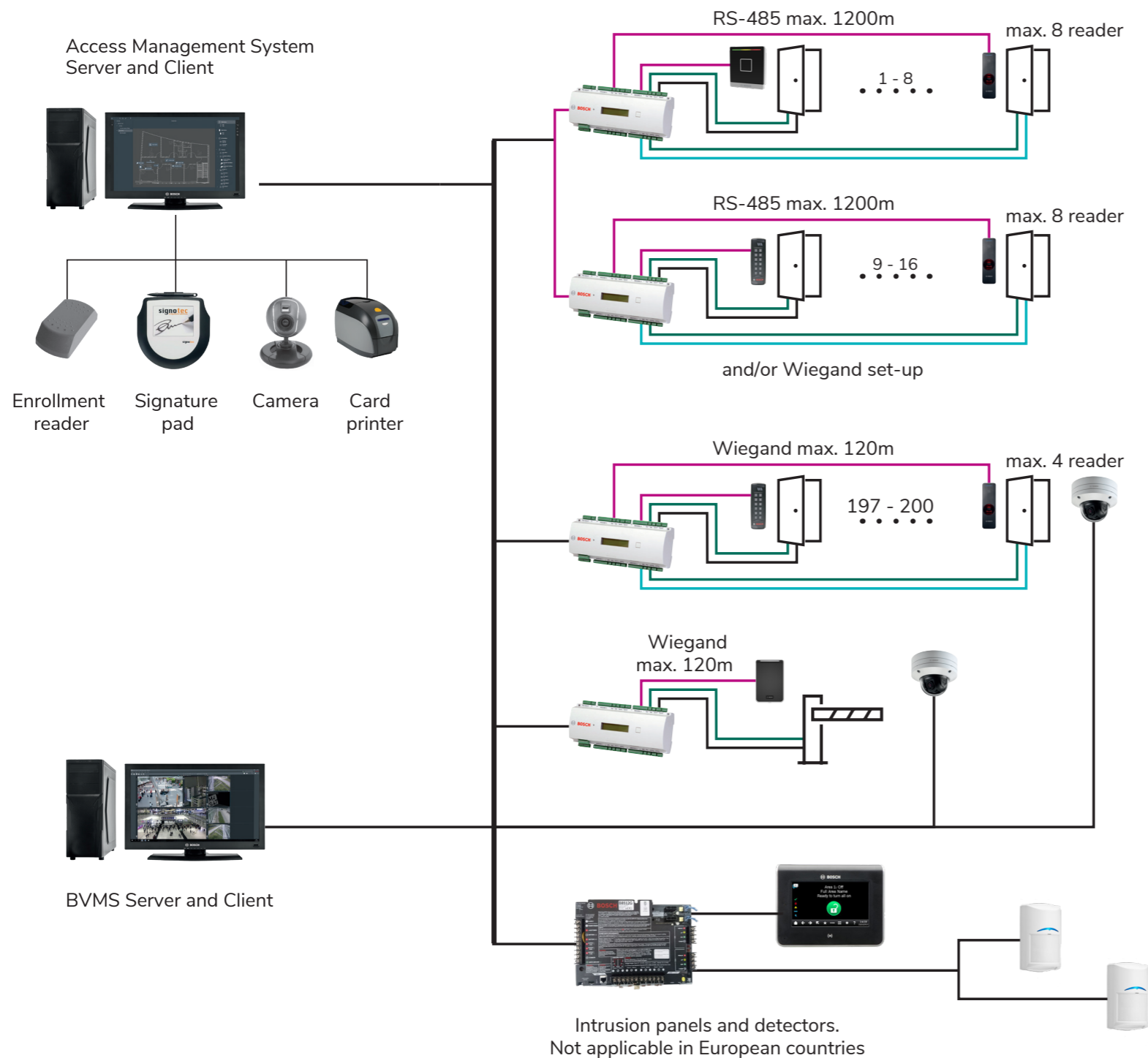

System description / application

System size

- 200 doors
- 1,200 cardholders
- Three operators

AMS Plus features

- Max. 288 doors
- Max. 10,000 cardholders
- 5 cards per person
- 1,024 authorizations per MAC
- Graphical location map
- Video integration for video verification via BVMS
- Credential management

AMC features

- 2 RS-485 buses or 4 Wiegand ports
- 8 inputs
- 8 relays
- TCP/IP, RS-485 connection

Reader features

- Support of OSDPV2 secure channel
- Outdoor resistant (up to IP67)
- Multitechnology support (125kHz and 13.56MHz)
- Wiegand and RS-485 support Keypad or fingerprint for verification

Access components

Access components	Item type
Readers	ARD-AYBS6380, ARD-FPBEW2-H3, ARD-SIGR40-ICL, ARD-SELECT-BO
Lock	to be purchased from 3rd party
Magnetic contact	ISN-CSM35-W
Request-to-exit	Request-to-exit Detector DS160
AMS Software	1 x AMS-BASE-PLUSxx**, 1 x AMS-XDRS-128Vxx, 2 x AMS-XCLI-1Vxx
Controller	APC-AMC2-4R4CF, APC-AMC2-4WCF
Power supply	APS-PSU-60
Battery	D126

Integrations

BVMS Software	
Cameras	
Intrusion control panel	B9512G
Intrusion touch screen keypad	B942
Intrusion detectors	CDL2-A15G



BOSCH

Access Control Systems

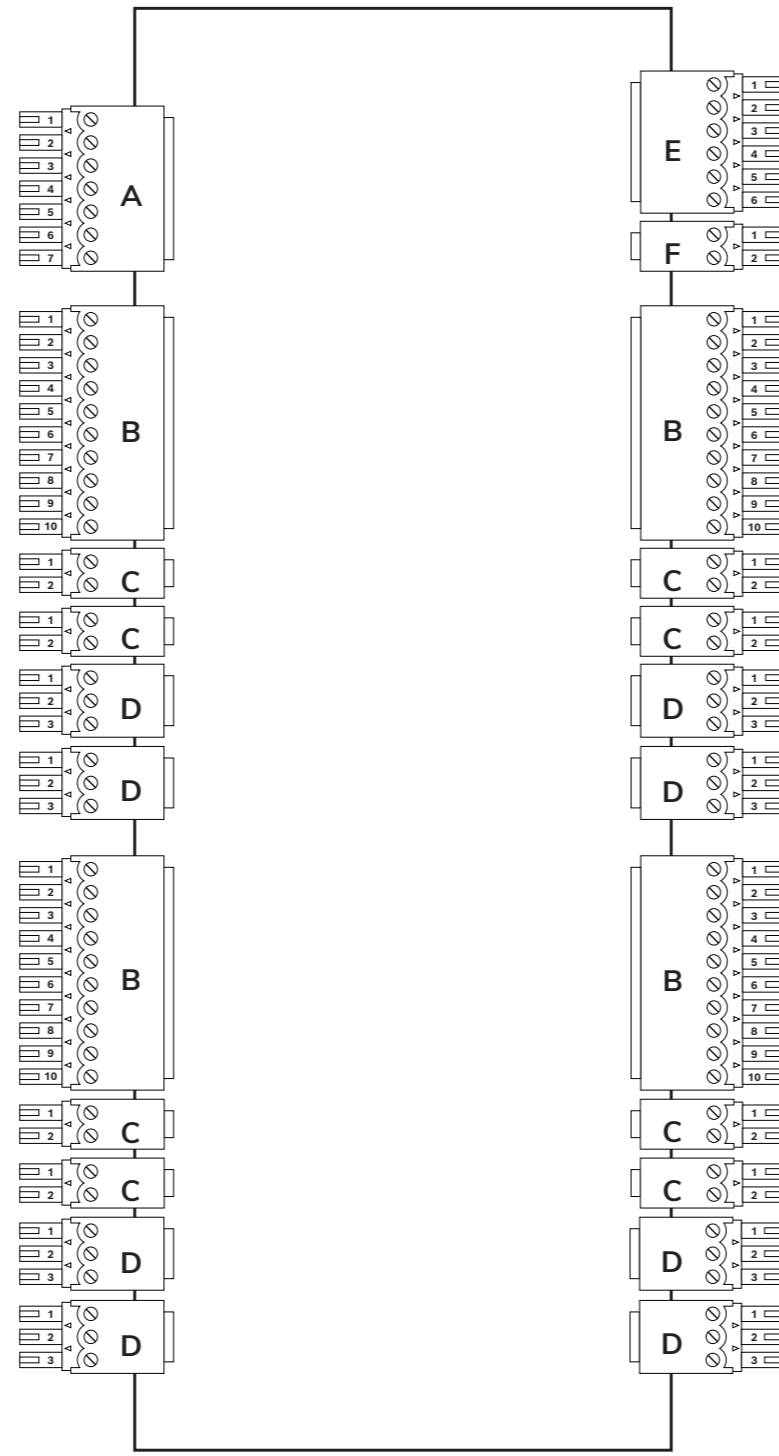
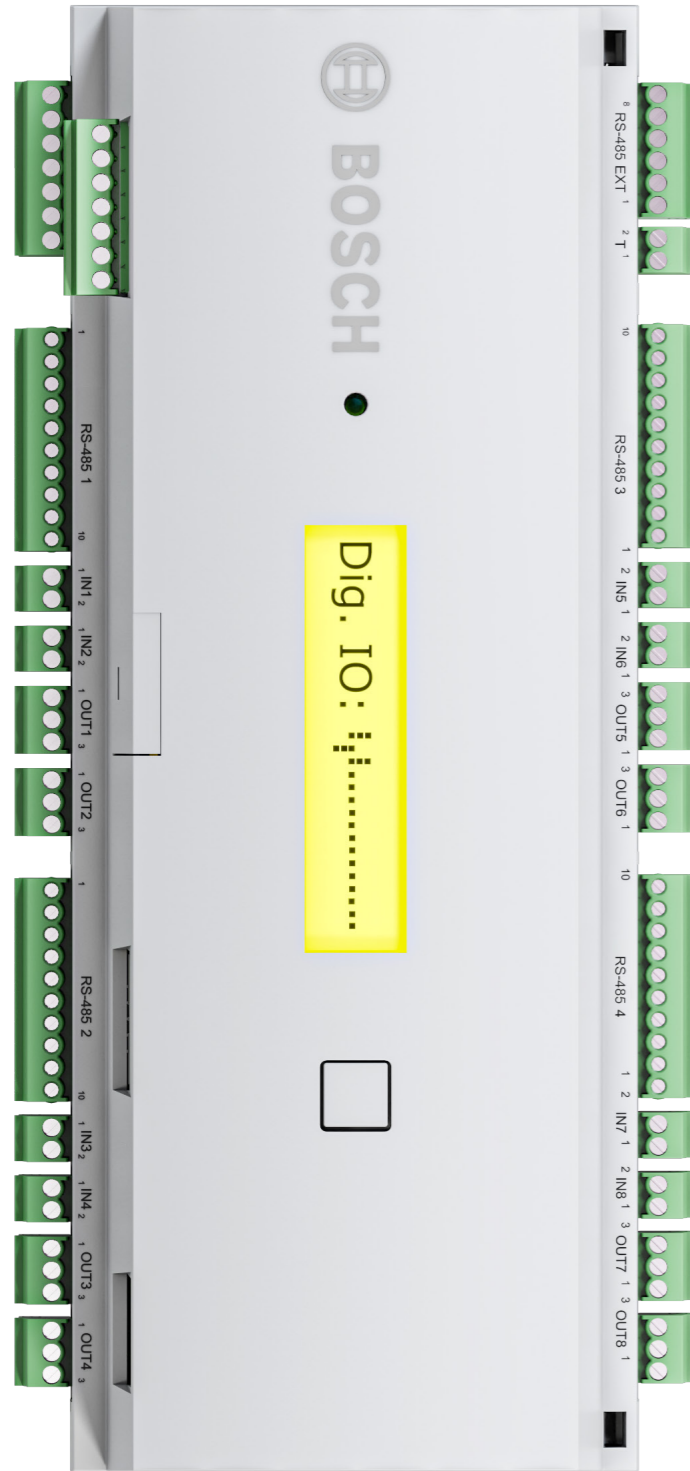

- A Power supply**
- | | |
|---|---------------------------------------|
| 1 | Power supply, DC positive (10V - 30V) |
| 2 | Shield |
| 3 | Power supply (0V) |
| 4 | UPS (power good signal) - AC |
| 5 | UPS (power good signal) - Battery |
| 6 | UPS (power good signal) - DC |
| 7 | UPS (power good signal) - Common |
- B RS-485 reader interface Wiegand interface AMC**
- | | | |
|----|---------------------------|---------------------|
| 1 | Reader Supply (10V - 30V) | Reader Supply (12V) |
| 2 | Reader Supply (0V) | Reader Supply (0V) |
| 3 | Shield | Data 0 |
| 4 | Data RxTx+ | Data 1 |
| 5 | Data RxTx- | Shield |
| 6 | Data shield (PAG) | green LED |
| 7 | not connected | red LED |
| 8 | not connected | Beeper |
| 9 | not connected | Hold |
| 10 | not connected | Card Present |
- C Analog input**
- | | |
|---|-------------------|
| 1 | Analog input, in |
| 2 | Analog input, out |
- D Relay output**
- | | |
|---|-------------------------------|
| 1 | Relay Output, normally open |
| 2 | Relay Output, common |
| 3 | Relay Output, normally closed |
- E Host/Extension Interface**
- | | |
|---|---|
| 1 | Power supply for external devices (10V - 30V) |
| 2 | Power supply for external devices (0V) |
| 3 | Shield |
| 4 | Data RxTx+ |
| 5 | Data RxTx- |
| 6 | Ground (PAG) |
- F External tamper contact**
- | | |
|---|---------------------|
| 1 | Tamper contact, in |
| 2 | Tamper contact, out |

RS-485 AMC2-4R4CF

Wiring diagram - 2 doors

1 door with two readers, door contact and lock per door application

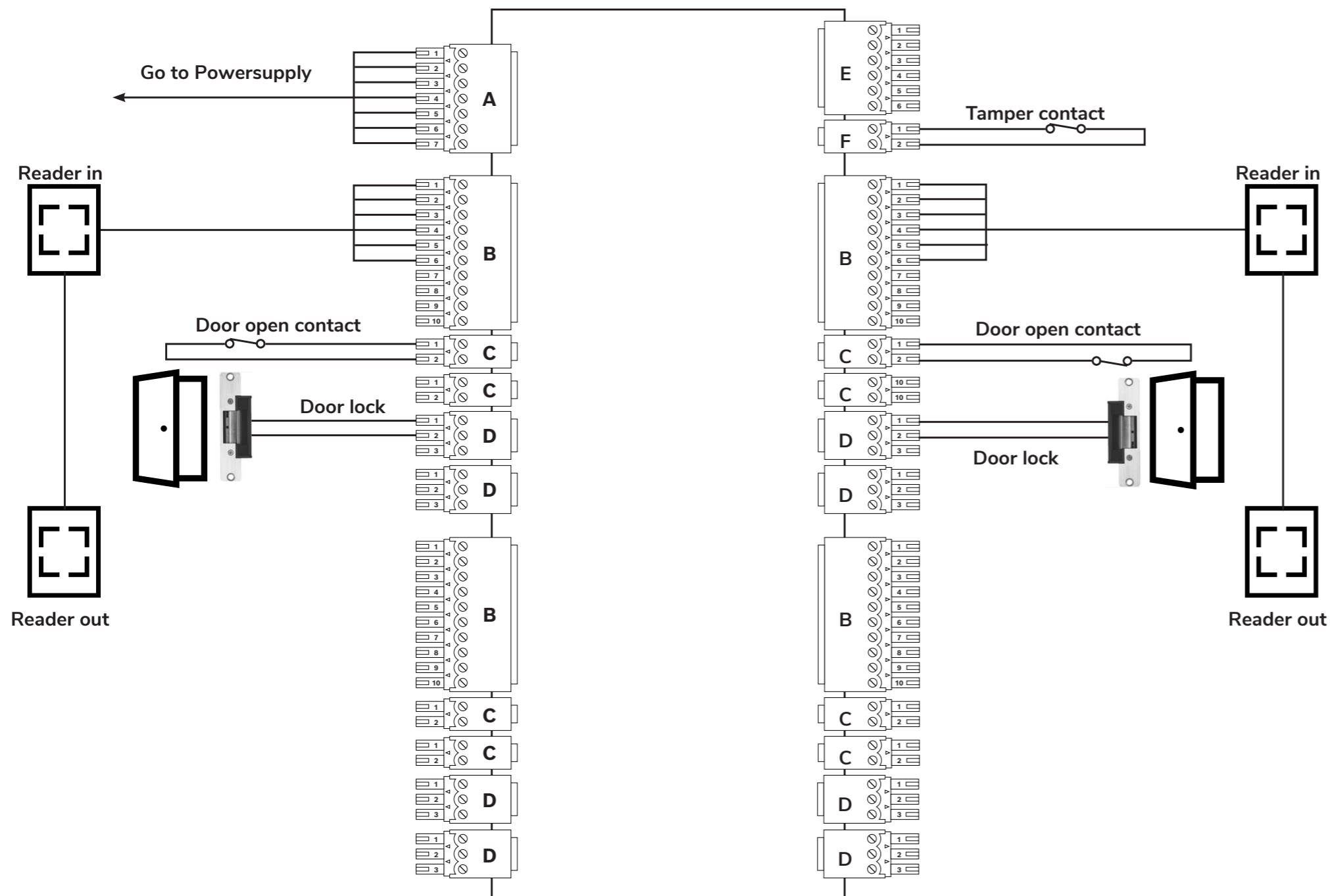

A Power supply	
1	Power supply, DC positive (10V - 30V)
2	Shield
3	Power supply (0V)
4	UPS (power good signal) - AC
5	UPS (power good signal) - Battery
6	UPS (power good signal) - DC
7	UPS (power good signal) - Common

B RS-485 reader interface	
1	Reader Supply (10V - 30V)
2	Reader Supply (0V)
3	Shield
4	Data RxTx+
5	Data RxTx-
6	Data shield (PAG)
7	not connected
8	not connected
9	not connected
10	not connected

C Analog input	
1	Analog input, in
2	Analog input, out

D Relay output	
1	Relay Output, normally open
2	Relay Output, common
3	Relay Output, normally closed

E Host/Extension Interface	
1	Power supply for external devices (10V - 30V)
2	Power supply for external devices (0V)
3	Shield
4	Data RxTx+
5	Data RxTx-
6	Ground (PAG)

F External tamper contact	
1	Tamper contact, in
2	Tamper contact, out

RS-485 AMC2-4R4CF

Wiring diagram - 4 doors

Entrance set-up with 1 reader and 1 request-to-exit button per door application

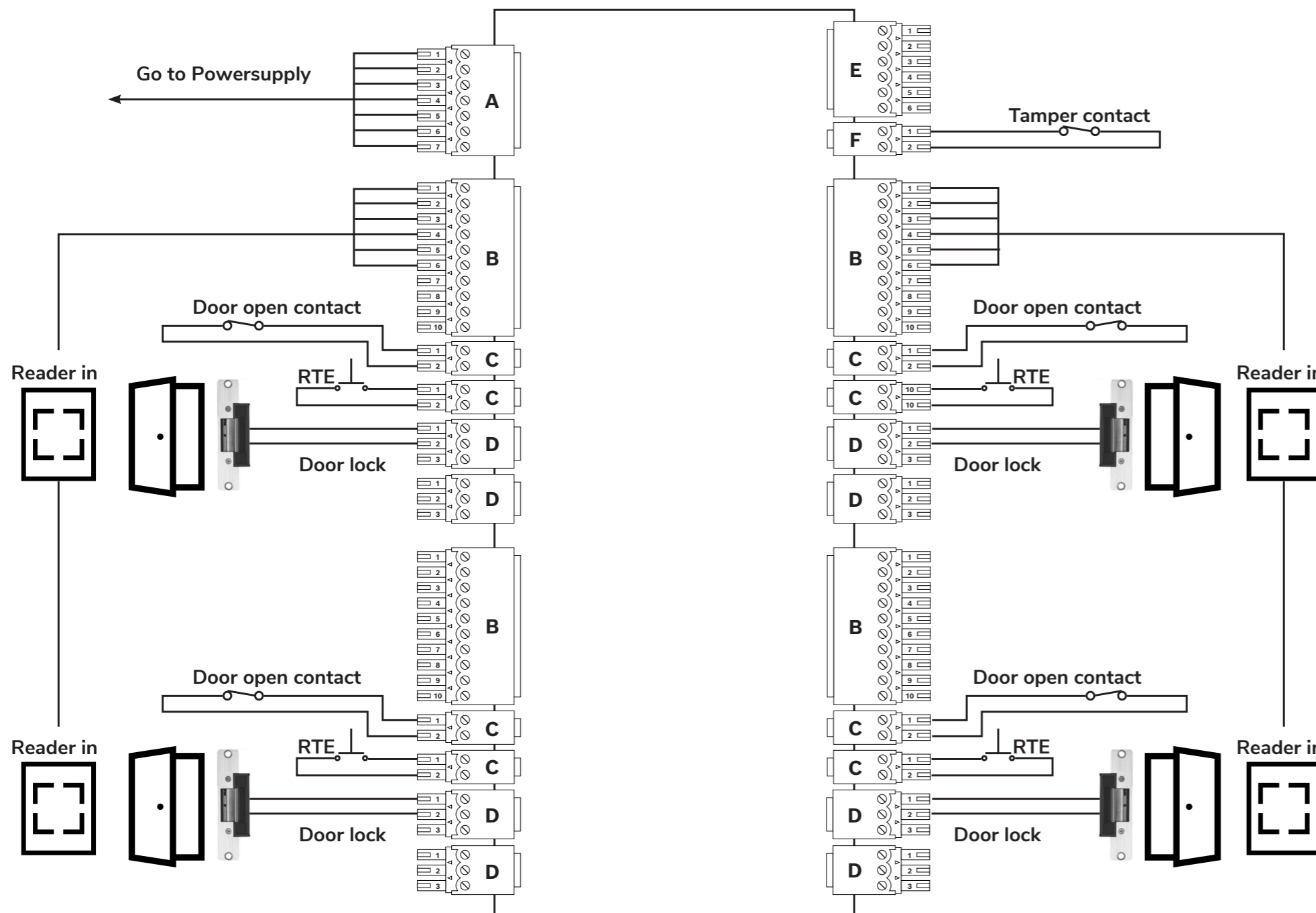
A
Power supply

- 1 Power supply, DC positive (10V - 30V)
- 2 Shield
- 3 Power supply (0V)
- 4 UPS (power good signal) - AC
- 5 UPS (power good signal) - Battery
- 6 UPS (power good signal) - DC
- 7 UPS (power good signal) - Common

B
RS-485 reader interface

- 1 Reader Supply (10V - 30V)
- 2 Reader Supply (0V)
- 3 Shield
- 4 Data RxTx+
- 5 Data RxTx-
- 6 Data shield (PAG)
- 7 not connected
- 8 not connected
- 9 not connected
- 10 not connected

C
Analog input

- 1 Analog input, in
- 2 Analog input, out

D
Relay output

- 1 Relay Output, normally open
- 2 Relay Output, common
- 3 Relay Output, normally closed

E
Host/Extension Interface

- 1 Power supply for external devices (10V - 30V)
- 2 Power supply for external devices (0V)
- 3 Shield
- 4 Data RxTx+
- 5 Data RxTx-
- 6 Ground (PAG)

F
External tamper contact

- 1 Tamper contact, in
- 2 Tamper contact, out

RS-485 AMC2-4R4CF

Wiring diagram - 8 doors

Entrance set-up with 1 reader and 1 request-to-exit button per door application

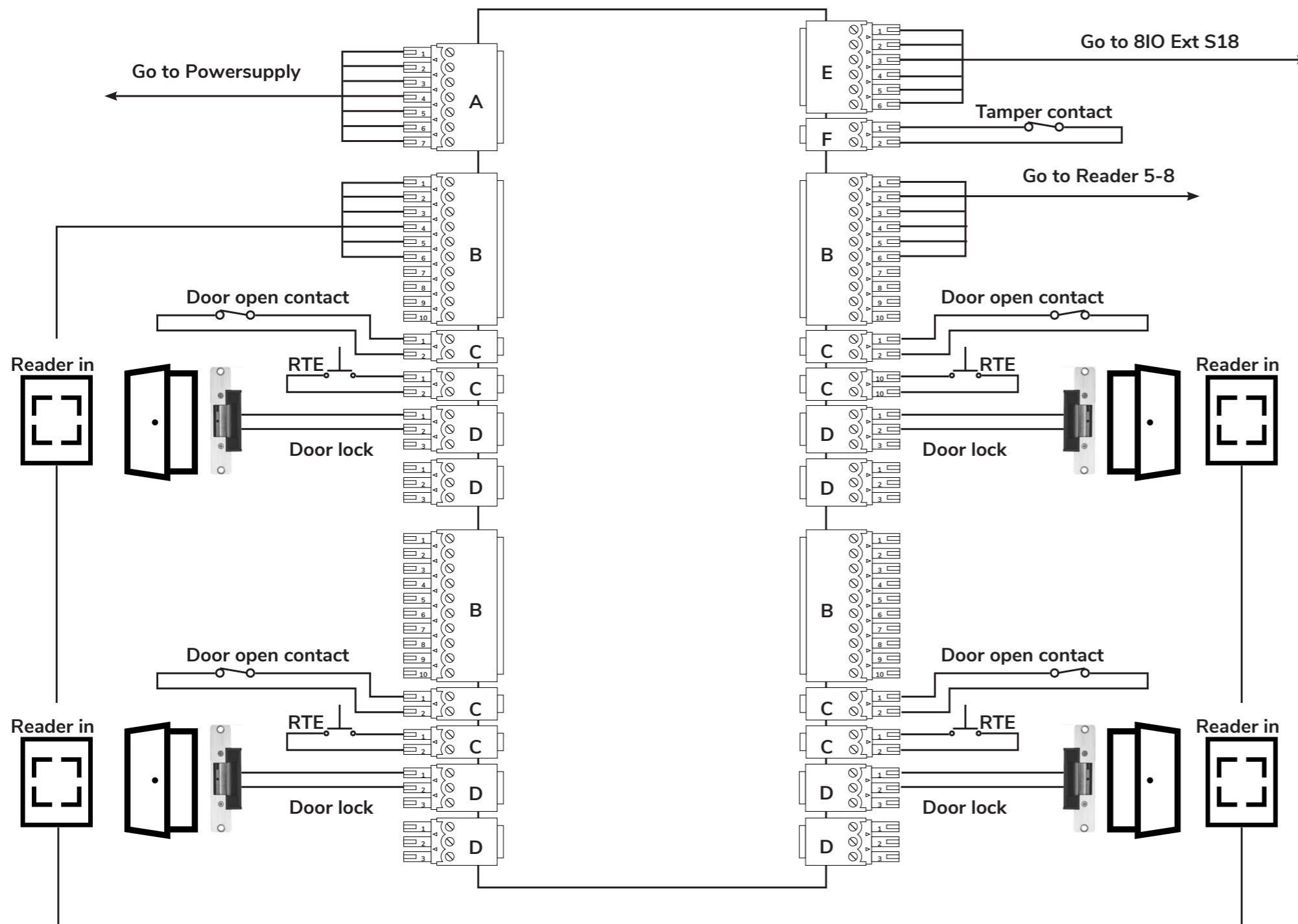
A
Power supply

- | | |
|---|---------------------------------------|
| 1 | Power supply, DC positive (10V - 30V) |
| 2 | Shield |
| 3 | Power supply (0V) |
| 4 | UPS (power good signal) - AC |
| 5 | UPS (power good signal) - Battery |
| 6 | UPS (power good signal) - DC |
| 7 | UPS (power good signal) - Common |

B
RS-485 reader interface

- | | |
|----|---------------------------|
| 1 | Reader Supply (10V - 30V) |
| 2 | Reader Supply (0V) |
| 3 | Shield |
| 4 | Data RxTx+ |
| 5 | Data RxTx- |
| 6 | Data shield (PAG) |
| 7 | not connected |
| 8 | not connected |
| 9 | not connected |
| 10 | not connected |

C
Analog input

- | | |
|---|-------------------|
| 1 | Analog input, in |
| 2 | Analog input, out |

D
Relay output

- | | |
|---|-------------------------------|
| 1 | Relay Output, normally open |
| 2 | Relay Output, common |
| 3 | Relay Output, normally closed |

E
Host/Extension Interface

- | | |
|---|---|
| 1 | Power supply for external devices (10V - 30V) |
| 2 | Power supply for external devices (0V) |
| 3 | Shield |
| 4 | Data RxTx+ |
| 5 | Data RxTx- |
| 6 | Ground (PAG) |

F
External tamper contact

- | | |
|---|---------------------|
| 1 | Tamper contact, in |
| 2 | Tamper contact, out |

Extension unit

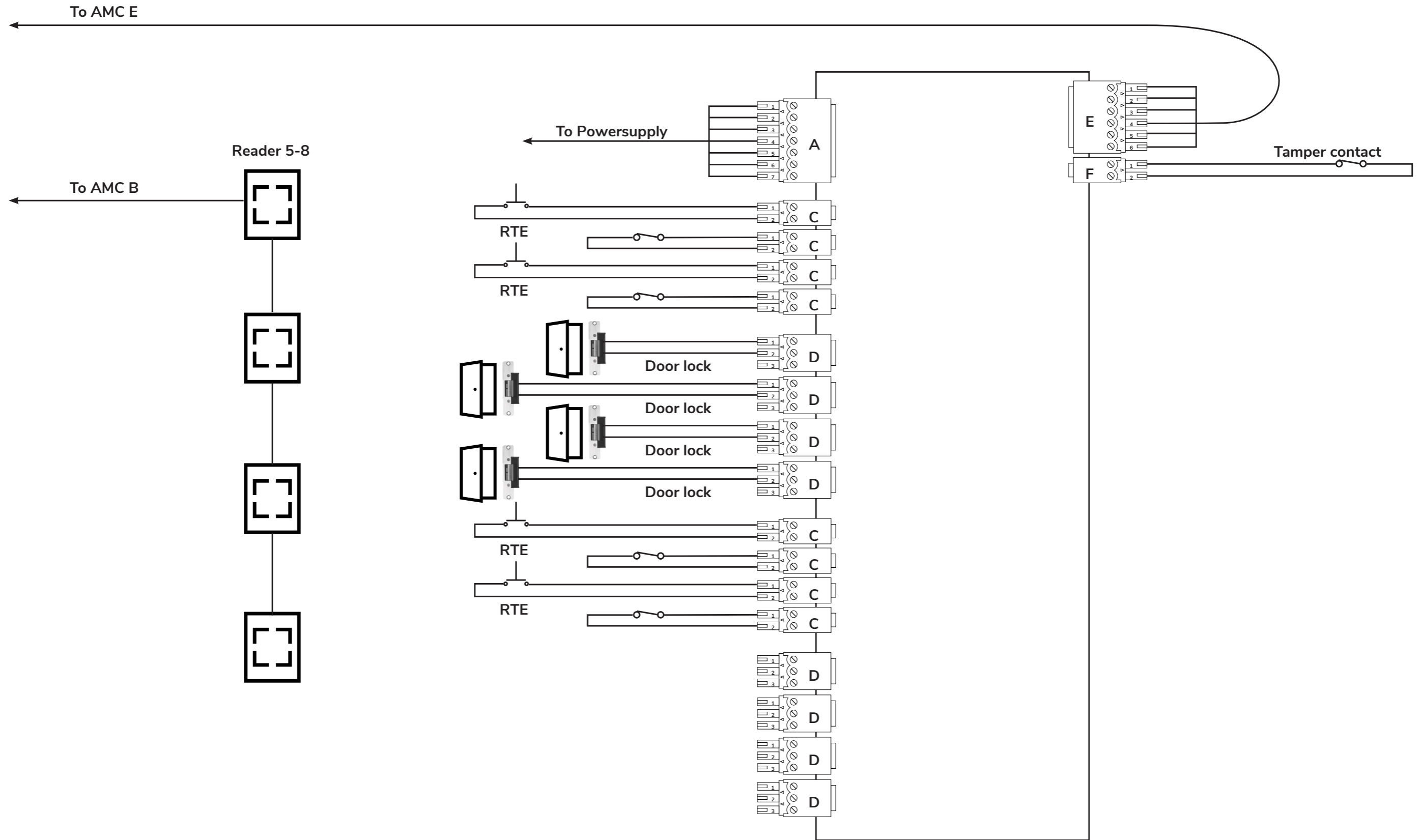

Wiegand AMC2-2WCF

Wiring diagram - 2 doors

Entrance set-up with 1 reader and 1 request-to-exit button per door application

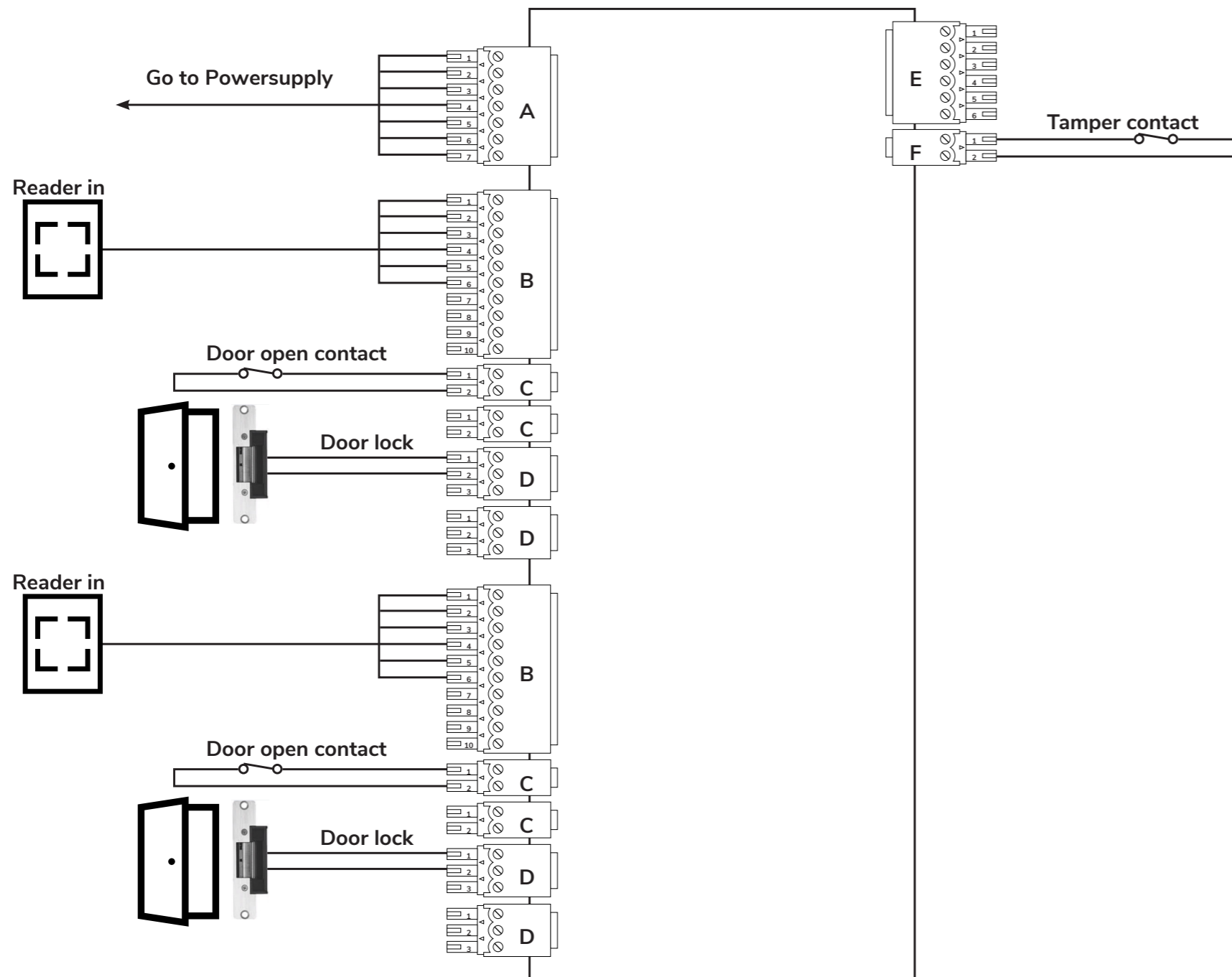
A
Power supply

- | | |
|---|---------------------------------------|
| 1 | Power supply, DC positive (10V - 30V) |
| 2 | Shield |
| 3 | Power supply (0V) |
| 4 | UPS (power good signal) - AC |
| 5 | UPS (power good signal) - Battery |
| 6 | UPS (power good signal) - DC |
| 7 | UPS (power good signal) - Common |

B
Wiegand interface AMC

- | | |
|----|---------------------|
| 1 | Reader Supply (12V) |
| 2 | Reader Supply (0V) |
| 3 | Data 0 |
| 4 | Data 1 |
| 5 | Shield |
| 6 | green LED |
| 7 | red LED |
| 8 | Beeper |
| 9 | Hold |
| 10 | Card Present |

C
Analog input

- | | |
|---|-------------------|
| 1 | Analog input, in |
| 2 | Analog input, out |

D
Relay output

- | | |
|---|-------------------------------|
| 1 | Relay Output, normally open |
| 2 | Relay Output, common |
| 3 | Relay Output, normally closed |

E
Host/Extension Interface

- | | |
|---|---|
| 1 | Power supply for external devices (10V - 30V) |
| 2 | Power supply for external devices (0V) |
| 3 | Shield |
| 4 | Data RxTx+ |
| 5 | Data RxTx- |
| 6 | Ground (PAG) |

F
External tamper contact

- | | |
|---|---------------------|
| 1 | Tamper contact, in |
| 2 | Tamper contact, out |

Wiegand AMC2-4WCF

Wiring diagram - 4 doors

Entrance set-up with 1 reader and 1 request-to-exit button per door application

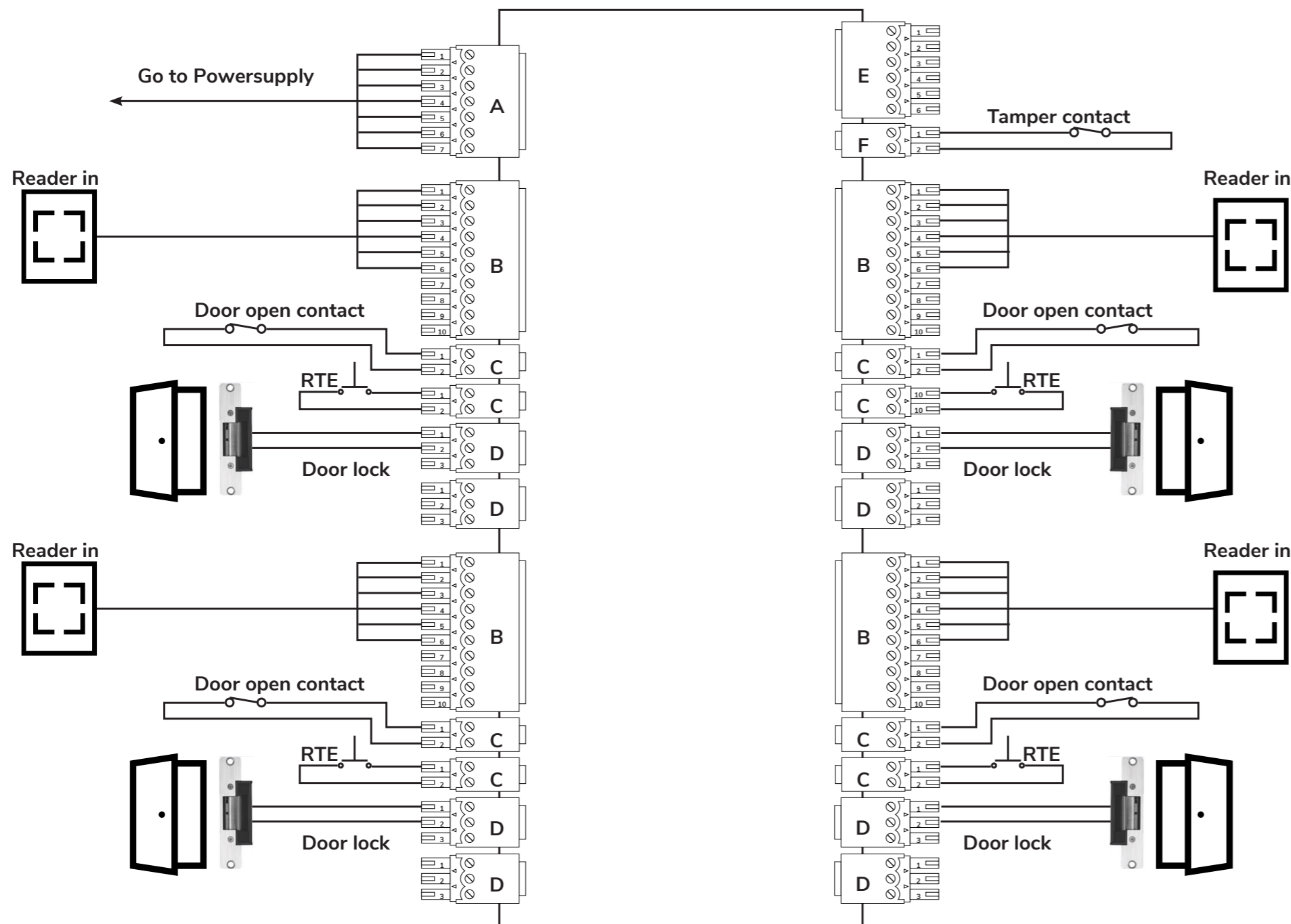
A
Power supply

- | | |
|---|---------------------------------------|
| 1 | Power supply, DC positive (10V - 30V) |
| 2 | Shield |
| 3 | Power supply (0V) |
| 4 | UPS (power good signal) - AC |
| 5 | UPS (power good signal) - Battery |
| 6 | UPS (power good signal) - DC |
| 7 | UPS (power good signal) - Common |

B
Wiegand interface AMC

- | | |
|----|---------------------|
| 1 | Reader Supply (12V) |
| 2 | Reader Supply (0V) |
| 3 | Data 0 |
| 4 | Data 1 |
| 5 | Shield |
| 6 | green LED |
| 7 | red LED |
| 8 | Beeper |
| 9 | Hold |
| 10 | Card Present |

C
Analog input

- | | |
|---|-------------------|
| 1 | Analog input, in |
| 2 | Analog input, out |

D
Relay output

- | | |
|---|-------------------------------|
| 1 | Relay Output, normally open |
| 2 | Relay Output, common |
| 3 | Relay Output, normally closed |

E
Host/Extension Interface

- | | |
|---|---|
| 1 | Power supply for external devices (10V - 30V) |
| 2 | Power supply for external devices (0V) |
| 3 | Shield |
| 4 | Data RxTx+ |
| 5 | Data RxTx- |
| 6 | Ground (PAG) |

F
External tamper contact

- | | |
|---|---------------------|
| 1 | Tamper contact, in |
| 2 | Tamper contact, out |

Wiegand AMC2-4WCF

Wiring diagram - 8 doors

Entrance set-up with 1 reader and 1 request-to-exit button per door application

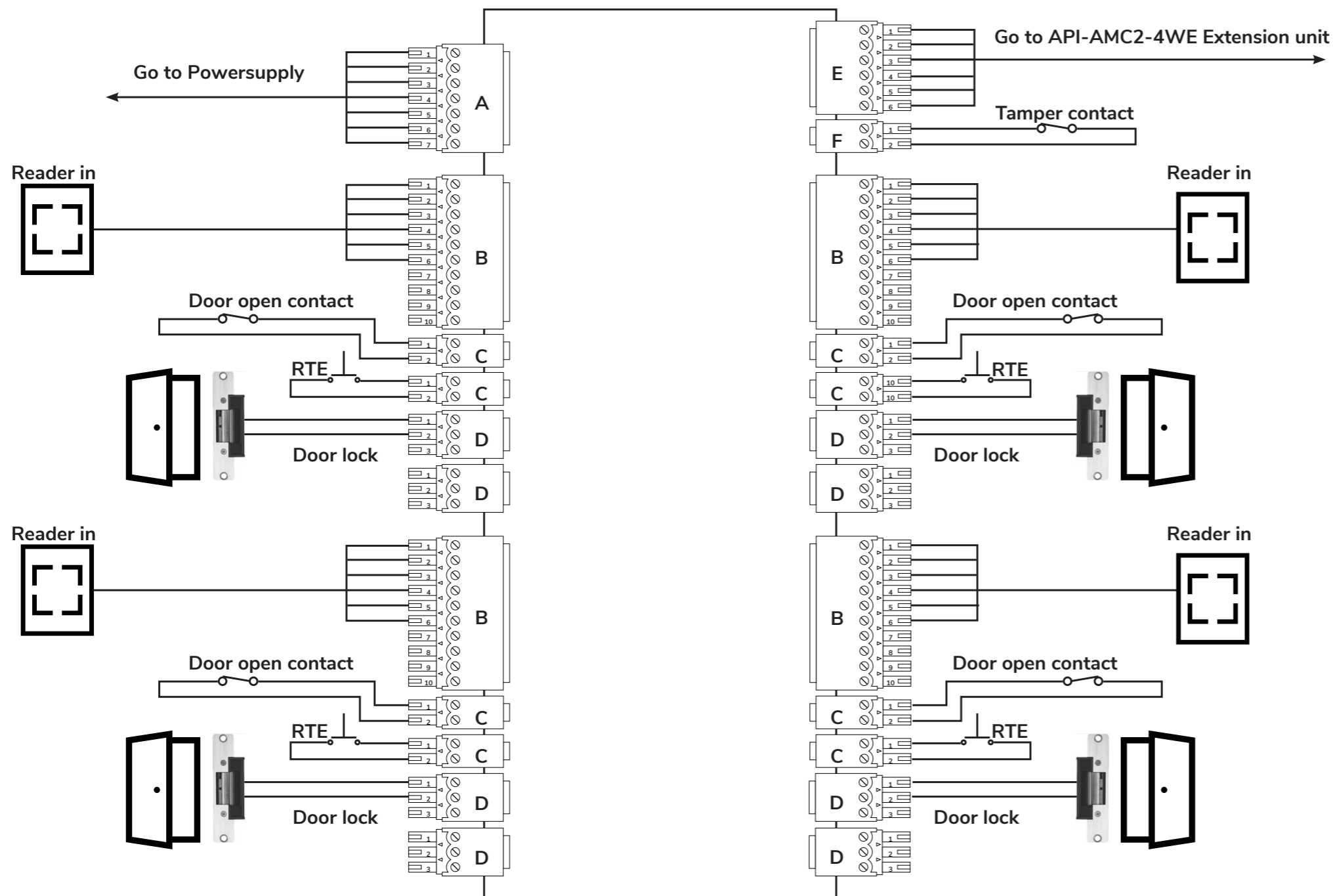
A
Power supply

- 1 Power supply, DC positive (10V - 30V)
- 2 Shield
- 3 Power supply (0V)
- 4 UPS (power good signal) - AC
- 5 UPS (power good signal) - Battery
- 6 UPS (power good signal) - DC
- 7 UPS (power good signal) - Common

B
Wiegand interface AMC

- 1 Reader Supply (12V)
- 2 Reader Supply (0V)
- 3 Data 0
- 4 Data 1
- 5 Shield
- 6 green LED
- 7 red LED
- 8 Beeper
- 9 Hold
- 10 Card Present

C
Analog input

- 1 Analog input, in
- 2 Analog input, out

D
Relay output

- 1 Relay Output, normally open
- 2 Relay Output, common
- 3 Relay Output, normally closed

E
Host/Extension Interface

- 1 Power supply for external devices (10V - 30V)
- 2 Power supply for external devices (0V)
- 3 Shield
- 4 Data RxTx+
- 5 Data RxTx-
- 6 Ground (PAG)

F
External tamper contact

- 1 Tamper contact, in
- 2 Tamper contact, out

Wiegand Extension API-AMC2-4WE unit

Wiring diagram - 8 doors

Entrance set-up with 1 reader and 1 request-to-exit button per door application

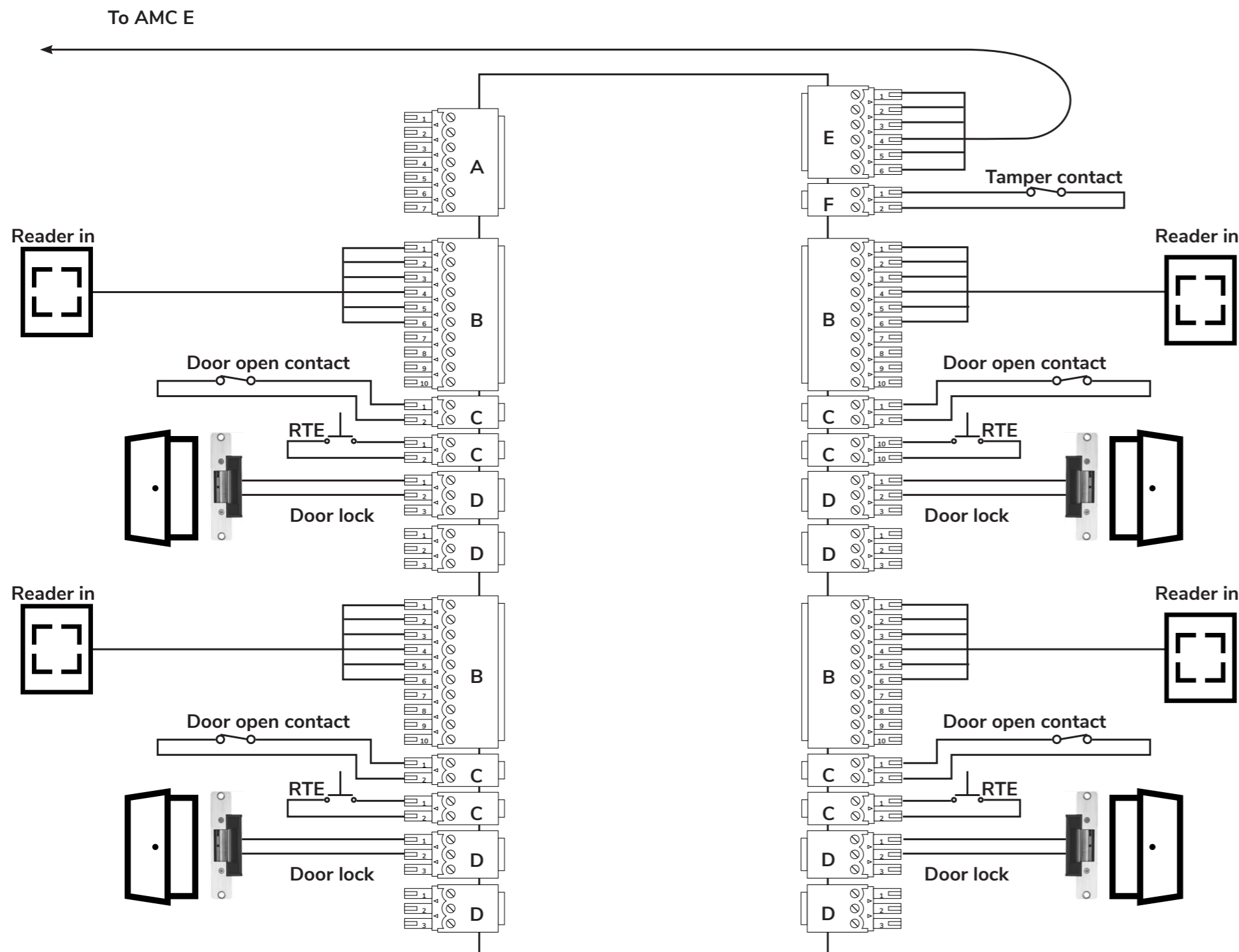
A
Power supply

- | | |
|---|---------------------------------------|
| 1 | Power supply, DC positive (10V - 30V) |
| 2 | Shield |
| 3 | Power supply (0V) |
| 4 | UPS (power good signal) - AC |
| 5 | UPS (power good signal) - Battery |
| 6 | UPS (power good signal) - DC |
| 7 | UPS (power good signal) - Common |

B
Wiegand interface AMC

- | | |
|----|---------------------|
| 1 | Reader Supply (12V) |
| 2 | Reader Supply (0V) |
| 3 | Data 0 |
| 4 | Data 1 |
| 5 | Shield |
| 6 | green LED |
| 7 | red LED |
| 8 | Beeper |
| 9 | Hold |
| 10 | Card Present |

C
Analog input

- | | |
|---|-------------------|
| 1 | Analog input, in |
| 2 | Analog input, out |

D
Relay output

- | | |
|---|-------------------------------|
| 1 | Relay Output, normally open |
| 2 | Relay Output, common |
| 3 | Relay Output, normally closed |

E
Host/Extension Interface

- | | |
|---|---|
| 1 | Power supply for external devices (10V - 30V) |
| 2 | Power supply for external devices (0V) |
| 3 | Shield |
| 4 | Data RxTx+ |
| 5 | Data RxTx- |
| 6 | Ground (PAG) |

F
External tamper contact

- | | |
|---|---------------------|
| 1 | Tamper contact, in |
| 2 | Tamper contact, out |

Power supply ○

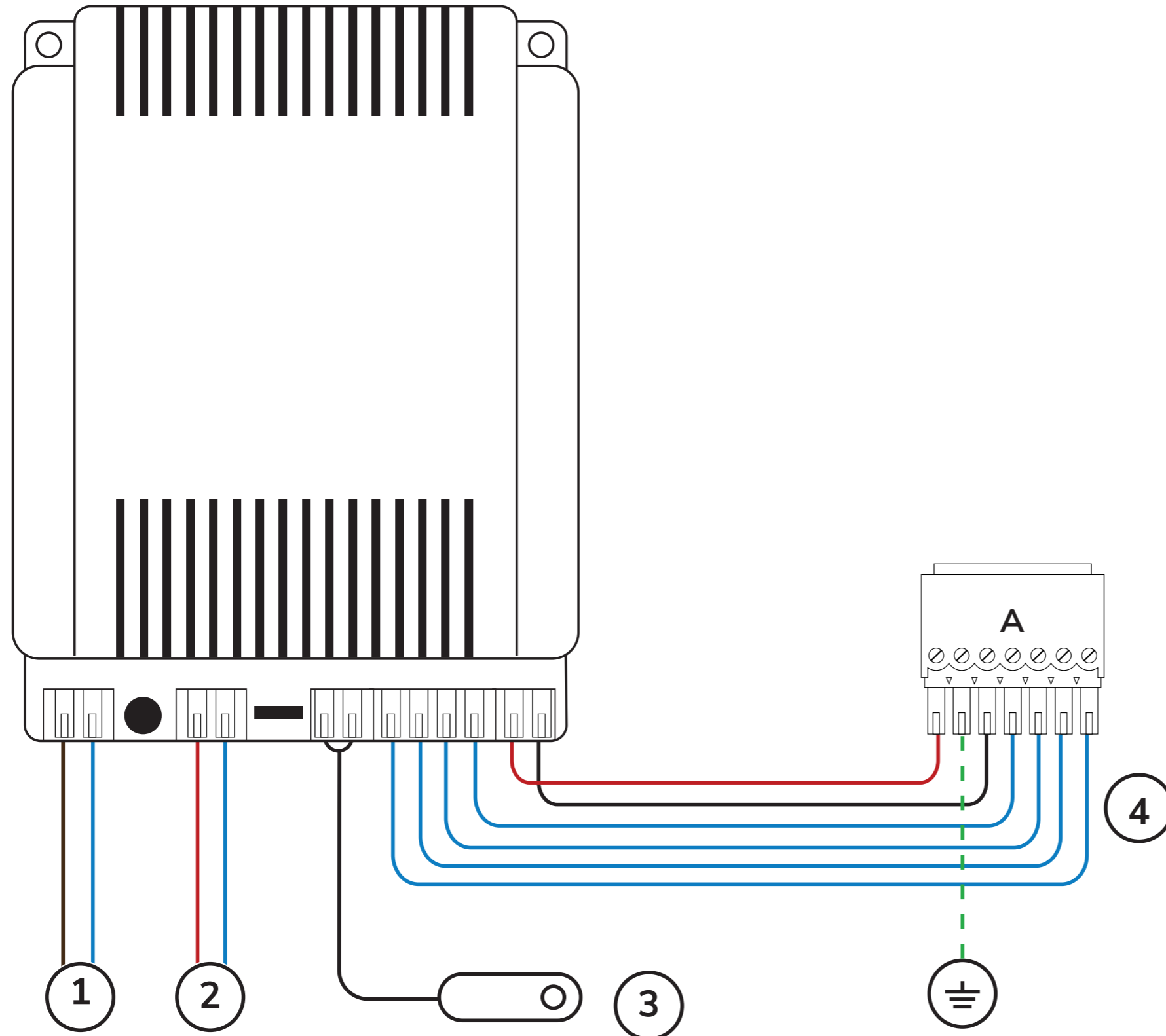
A
Power supply

- | | |
|---|---------------------------------------|
| 1 | Power supply, DC positive (10V - 30V) |
| 2 | Shield |
| 3 | Power supply (OV) |
| 4 | UPS (power good signal) - AC |
| 5 | UPS (power good signal) - Battery |
| 6 | UPS (power good signal) - DC |
| 7 | UPS (power good signal) - Common |

- | | |
|---|---------------------------------------|
| 1 | AC power (110/230 VAC) |
| 2 | Battery connection (12V - 7AH) |
| 3 | Temperature sensor |
| 4 | Power supply to AMC wiring connection |